

**4.75 IN/120.65MM
 TORPEDO DIA.**

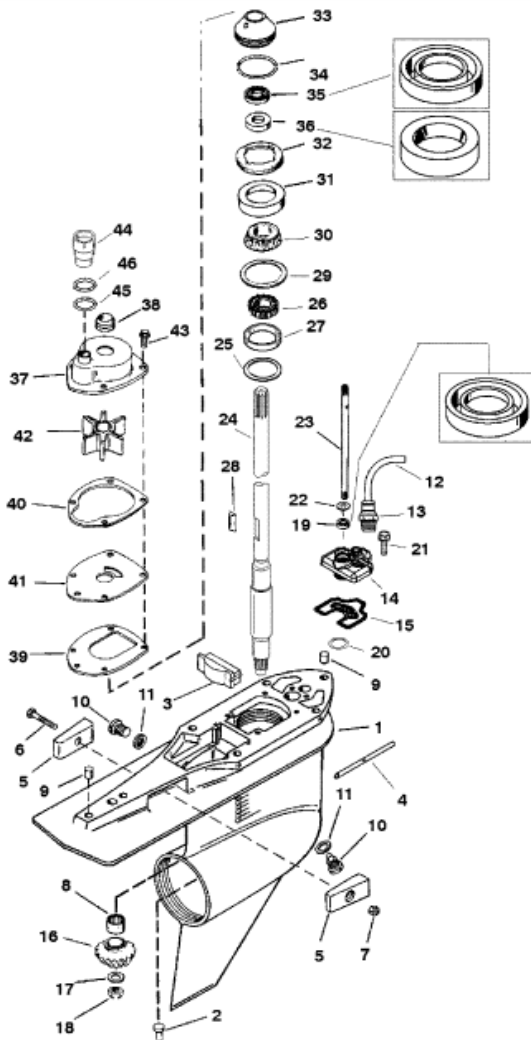

GEAR HOUSING (DRIVE SHAFT)(STANDARD ROTATION)

Parts List					
Ref	Class	Part	Description	Qty	Footnote
1	1623	859399T18	GEAR HOUSING (BASIC)	1	
2	17	37972 1	PIN	1	
3		821526	FILLER BLOCK	1	
4		859402	PITOT TUBE	1	
5		826134Q	ANODE	2	
6	10	40003 33	SCREW	1	
7	11	826833 6	NUT	1	
8	31	42647A 1	ROLLER BEARING	1	
9	17	43044	DOWEL PIN	2	
10	10	79953Q 2	SCREW ASSEMBLY	2	
11	12	19183 2	SEALING WASHER	2	15
12	32	859449 75	HOSE	1	(LONG - 7 IN)
12	32	859449 75	HOSE	1	(X-LONG - 12 IN)
12	32	859449 75	HOSE	1	(XX-LONG - 17 IN)
13	22	859432	CONNECTOR	1	
14		858934	COVER	1	
15	27	858935	GASKET	1	
16		NSS	PINION GEAR	1	(1.75:1 - 12/21)(PART OF 43-85934)
17	12	92721	WASHER	1	
18	11	35921	NUT	1	
19	26	816464 1	OIL SEAL	1	15
20	25	36318	O RING	1	15
21	10	19937 16	SCREW (M6 X 16)	2	
22	12	77674	RUBBER WASHER	1	
23		824145	SHIFT SHAFT (LOWER)	1	
24	45	881938	DRIVE SHAFT	1	(LONG)
24	45	881942	DRIVE SHAFT	1	(X-LONG)
24	45	881943	DRIVE SHAFT	1	(XX-LONG)
25	15	38657A 1	SHIM SET	AR	
26	31	48939A 2	TAPERED ROLLER BEARING	1	
27		NSS	CUP	1	
28	28	43037	KEY	1	18
29	15	42637A 1	SHIM SET	AR	
30	31	36387A 1	TAPERED ROLLER BEARING	1	
31		NSS	CUP	1	
32		824519 1	RETAINER	1	
33		807929A 1	CARRIER ASSEMBLY	1	18
34	25	90011	O RING	1	15,15
35	26	66302	OIL SEAL	1	15,18
36	26	66302	OIL SEAL	1	15,18
37		817275A 1	WATER PUMP ASSEMBLY	1	18